

1955 AMC-Hudson

Accessory Merchandising Bulletins

INDEX

No. 7 - Radio Price Slashed

No. 8 - New Outside Rear View Mirror

No. 9 - 1954 Accessory Prices Cut

No. 10 - 1955 Accessory Price Folder

No. 12 - Bargain Prices - 1955 Rambler Fog Lamps

No. 13 - 1955 Accessory Folder

No. 16 - Hudson Cooling System Chemicals

No. 20 - 1954 Accessory Price Reduction Withdrawn



HUDSON MOTORS

DIVISION OF AMERICAN MOTORS CORPORATION 14250 PLYMOUTH ROAD DETROIT 32, MICHIGAN

Accessory Merchandising Bulletin

Number

7

Date

3-14-55

Subject

RADIO
PRICE
SLASHED
!!

RADIO PRICES CUT !!!

RADIO - 6 TUBE - WASP

DEALER NET REDUCED TO \$31.12

Effective March 16, 1955, the resale price schedule on 1955 Wasp 6 tube Radio becomes:

<u>Part Number</u>	<u>Description</u>	<u>Dealer Net</u>	<u>E.O.H.</u>
8997500	RADIO - 6 TUBE 1955 WASP	31.12	2.25

Here's a real opportunity for increased Radio sales and profits. Now you can sell a Radio with every New 1955 Hudson Wasp.

Sell a FENDER MOUNTED ANTENNA too . . . for easy installation!

<u>Part Number</u>	<u>Description</u>	<u>Dealer Net</u>	<u>E.O.H.</u>
8990290	ANTENNA - MANUAL	4.35	.30

A genuine Radio bargain - a powerful 6 tube RADIO and a FENDER MOUNTED ANTENNA for 35.47 Plus tax.

Fill in the attached order blank today - right now! Mail it to your Parts Warehouse.

PLACE
YOUR
ORDER
TODAY
!

HUDSON MOTORS Division

American Motors Corporation

C. C. MC KELLAR
MANAGER

PARTS & ACCESSORY MERCHANDISING

DEALER TO PARTS WAREHOUSE ORDER BLANK

FOR

8997500 RADIO, 6 tube - 8990290 ANTENNA, Fender Mounted

ORDER NUMBER _____

DATE _____

PLEASE SHIP VIA: EXPRESS _____ TRUCK _____

OR INCLUDE WITH NEXT PREPAID ACCESSORY ORDER _____

<u>QUANTITY</u>	<u>PART NUMBER</u>	<u>DESCRIPTION</u>	<u>DEALER NET</u>	<u>E.O.H.</u>
_____	8997500	Radio - 6 tube 1955 WASP	31.12	2.25
_____	8990290	ANTENNA - FENDER MOUNTED	4.35	.30

AUTHORIZED SIGNATURE _____

DEALER NAME _____

STREET ADDRESS _____

CITY _____ STATE _____

(MAIL WHITE COPY TO YOUR PARTS WAREHOUSE)
(RETAIN COLORED COPY FOR YOUR FILE)



AMERICAN MOTORS CORPORATION

14250 PLYMOUTH ROAD

DETROIT 32, MICHIGAN

HUDSON AUTOMOBILES
NASH AUTOMOBILES
SPECIAL PRODUCTS

KELVINATOR
AND LEONARD
APPLIANCES

Accessory Merchandising Bulletin

Number

8

Date

3-17-55

Subject

NEW OUTSIDE

REAR VIEW

MIRROR

1948 - 1955

WASP, HORNET

AND RAMBLER

MODELS

PRICE

SCHEDULE

ORDER

TODAY

Announcing a new . . . A "OUTSIDE REAR VIEW MIRROR."

NEW from stem to stern . . . this custom styled mirror is quality plus!!!

For full rear view vision . . . It's smartly styled head features a large 4-1/2" diameter mirror on an exclusively designed base A A A assuring for the driver quick, easy, and firm adjustment.

The new mirror . . . provides a beautiful door mount installation that blends with the new "high style" of the 1955 Hornet, Wasp and Hudson Rambler.

"AVAILABLE FOR IMMEDIATE DELIVERY" . . . and priced to sell in volume - with full profit for the dealer.

PART NO.	DESCRIPTION	DEALER NET	SUGGEST LIST	E.O.H.
8990003	Outside Rear View Mirror	2.34	3.90	.15

People buy what they see . . . display it on show cars . . .

display it in the Parts Department, Service Department . . . suggest it to customers of 1948-54 models . . . excellent for brightening up used cars.

Order a substantial quantity with your next Prepaid Accessory Order.

A "SURE SELLER" FOR THE COMING - - -
SPRING AND SUMMER "DRESS-UP" SEASON

HUDSON MOTORS Division
American Motors Corporation

H. L. Templin

Parts & Accessory Merchandising

November 10, 1955

1956 FACTORY INSTALLED OPTIONS

<u>CODE</u>	<u>DESCRIPTION</u>	<u>OPTIONAL ON</u>
FC	Foam Cushion - Front & Rear	Rambler 5615 Basic & 5618-1 only
FF	Foam Cushion - Front Rambler	5615 Basic & 5618-1 only
FR	Foam Cushion - Rear	Optional on 5615,5615-1, 5618-1, 35645-1 35665-1. Compulsory on Rambler Custom Models,
SG	Solex-Glass	All Models - Comp. Option with AC
WW	Windshield Washer	All Models
RS	Reclining Seats	Optional 5615, 5615-1,5618-1, 35645-1, 35665-1. Compulsory an Rambler Custom Models
DS	Directional Signals	Compulsory Option All Rambler Models
WC	Wheel carrier	All Ramblers; less Station Wagon (Std. on Hornet Custom)
W	Less Wheel Carrier	Specify When carrier not wanted on Hornet 6&8 Custom
RM	Radio	All Models
WE	Weather Eye	All Models
AC	Air Conditioning	All Models
STD	Standard Transmission	All Models less Hornet Custom Models
C	Overdriye Transmission	All Models less Hornet Custom Models
H	Hydramatic Transmission	All Models less Hornet V-8
V	Ultramatic Transmission	Compulsory on Hornet V-8 only
CL	Electric Clock	Optional on 5615, 5615-1, 5618-1, 35645-1, Comp. on All Rambler Custom Models
OB	Oil Bath Air Cleaner	All Rambler Models
OF	Oil Filter	All Rambler Models and Wasp
4W	4 Ply White Wall Tires	All Models less 35687-2
6B	6 Ply Black Tires	All Models
6W	6 Ply White Wall Tires	All Models
WL	Window Lift	All Wasp and Hornet Models
TH	Dual Carburators	Wasp and Hornet Super Models
WD	Wheel Disc	35645-1, Comp. on Rambler Custom
HSP	Heavy Rear Springs & Shocks	All Models
FB	Power Brakes	Models 5615, 5615-1. 5618-1, 35645-1, 35665-1
PS	Power Steering	All Wasp & Hornet Models
BL	Back Up Lights	All Models less Hornet V-8
HO	Hood Ornament	Compulsory Option All Models



AMERICAN MOTORS CORPORATION

HUDSON AUTOMOBILES
NASH AUTOMOBILES
HUDSON SPECIAL PRODUCTS

14250 PLYMOUTH ROAD
DETROIT 32 MICHIGAN

KELVINATOR
AND LEONARD
APPLIANCES

Accessory Merchandising Bulletin

Number
9

Date
3-29-55

SALE SALE SALE

1954 ACCESSORIES PRICES
SLASHED . . .

Subject

Effective Monday morning, March 28, 1955, all 1954 Accessories prices are reduced to less than cost.

Attached is a SPECIAL ACCESSORIES PRICE LIST for 1954 Models which includes hundreds of amazing bargains that you won't be able to resist.

Our confidential advice to you CHECK THE PRICE LIST IMMEDIATELY and PLACE YOUR ORDER for all of the Accessories you can SELL to Service Customers, INSTALL ON New 1954 Models and INSTALL ON Used Cars and DO IT right now!

The supply is limited to the inventory now on hand. Orders will be filled as long as the supply lasts.

DON'T DELAY . . . ORDER 1954 ACCESSORIES

BARGAINS TODAY !

HUDSON MOTORS Division
American Motors Corporation

C. C. MC KELLAR

MANAGER
PARTS & ACCESSORY MERCHANDISING

1954
ACCESSORIES
PRICES
CUT
TO THE
BONE



AMERICAN MOTORS CORPORATION

HUDSON AUTOMOBILES
NASH AUTOMOBILES
HUDSON SPECIAL PRODUCTS

14250 PLYMOUTH ROAD
DETROIT 32 MICHIGAN

KELVINATOR
AND LEONARD
APPLIANCES

Accessory Merchandising Bulletin

Number
10

Date
4-5-55

NEW.....

1955 ACCESSORY PRICE FOLDER

Subject

1955
ACCESSORY
PRICE
FOLDER

HANDY
SIZE

ALWAYS
KEEP IN
COAT
POCKET

Attached is the 1955 Accessory Price Folder which includes all Accessories applicable to 1955 Rambler, Wasp and Hornet Models.

The Accessory Price Folder is available to Hudson Dealers on a gratis basis.

Description, model application, part number and suggested list price are shown for each item. Under the heading "Installation Time" should be added the local installed prices.

Every Hudson Retail Salesman will want to carry the Accessory Price Folder with the Car Price and Equipment Folder to have complete information for New Car Prospects.

Service Managers, Service Salesmen, Parts Managers and Counter Men should always have this Folder on their person, ready to show New Car Buyers and Service Customers the full line of Accessories available and their installed prices.

HUDSON MOTORS Division
American Motors Corporation

C. C. MC KELLAR

MANAGER
PARTS & ACCESSORY MERCHANDISING

RECOMMENDATIONS FOR USE OF ACCESSORY FOLDER

1. The ACCESSORY FOLDER is a companion piece to all New Car Catalogs and literature. Wherever New Car Catalogs are displayed and used, the ACCESSORY FOLDER should also be displayed and used - in the New Car Showroom, the Service Receiving Desk and the Parts Counter.
2. Always give New Car Prospects ACCESSORY FOLDERS with New Car Catalogs.
3. When closing New Car Sales, the ACCESSORY FOLDER helps to sell the extra equipment that builds up the gross profit.
4. Mail ACCESSORY FOLDERS to New Car Buyers approximately ten days after the car is delivered. This will stimulate interest and you will get a second chance to sell Accessories at the 1,000 mile and 2,000 mile inspections.
5. Mail ACCESSORY FOLDERS to your Owners of 1953 and 1954 Model Hudsons. There is an excellent market for the Accessories on late model cars.



AMERICAN MOTORS CORPORATION

HUDSON AUTOMOBILES
NASH AUTOMOBILES
HUDSON SPECIAL PRODUCTS

14250 PLYMOUTH ROAD
DETROIT 32 MICHIGAN

KELVINATOR
AND LEONARD
APPLIANCES

Accessory Merchandising Bulletin

A profit making suggestion for your May Safety Campaign

"SELL GENUINE HUDSON FOG LAMPS"
AT THESE BARGAIN PRICES.

<u>GROUP NO.</u>	<u>PART NO.</u>	<u>DESCRIPTION</u>	<u>LIST-PRICE</u>	<u>DEALER NET</u>	<u>E.O.H.</u>
15.160	8990160	Fog Lamp, Pr.	5.75	3.35	.25
15.160	8990161	Fog Lamp, Inst. Kit	.45	.25	.05

ADAPTABLE TO 1955 MODEL RAMBLERS and priced for volume sales . . .
Hudson Fog Lamps are a "natural" to promote during the month of May.

Your Rambler customers will buy this outstanding bargain in "safety."

Equip Show Room Ramblers and Demonstrators with Fog Lamps so prospects will see the exceptional quality of this accessory and how beautifully it blends with the Rambler Styling.

Display Fog Lamps in your Service Department, and Parts Department, with the low retail price a part of each display.

Display in Show Room Windows with other accessories. "key-note" safe driving.

Don't overlook your customers who have already purchased a Rambler, they will want to know of this outstanding buy . . . a post card will do the trick.

REMEMBER, each Fog Lamp sale presents an opportunity to sell additional accessories for additional profits.

"PLACE YOUR ORDER NOW"

the supply of Hudson Fog Lamps is limited and at the unusually low prices they will go fast.

HUDSON MOTORS Division
American Motors Corporation

H. L. Templin

Parts & Accessory Merchandising

Number
12

Date
5-3-55

Subject
BARGAIN PRICES
ON
1955 RAMBLER
FOG LAMPS

HERE'S
HOW
TO
SELL 'EM

ORDER
NOW



AMERICAN MOTORS CORPORATION

HUDSON AUTOMOBILES
NASH AUTOMOBILES
HUDSON SPECIAL PRODUCTS

14250 PLYMOUTH ROAD
DETROIT 32 MICHIGAN

KELVINATOR
AND LEONARD
APPLIANCES

Accessory Merchandising Bulletin

Enclosed is your initial supply of the beautiful 1955 ACCESSORY FOLDER . . . a real sales-getter that will create the desire to buy Hudson Accessories.

The ACCESSORY FOLDER'S message is addressed to Hudson Prospects and Owners: "FOR YOUR MOTORING ENJOYMENT."

Accessories are grouped in four categories:

- (1) Listening Pleasure
- (2) Comfort and Convenience
- (3) Greater Beauty ... Luxury ... Splendor
- (4) Safer Driving

The beautiful illustrations are actual photographs. They show what each accessory does for the car and the driver and how it functions. The descriptions are brief, full of interesting understandable information to make your Customers want to buy these accessories.

This three color ACCESSORY FOLDER is an excellent mailing piece to your Late Model Owners. It will let your prospects see at a glance the impressive accessories you have available. Attached is a list of recommendations to help you use the ACCESSORY FOLDER to best advantage.

Additional quantities of FOLDERS are available through your Zone Office. Place your request with the Zone Manager and shipment will be made direct from Detroit.

HUDSON MOTORS Division
American Motors Corporation

C. C. MC KELLAR

MANAGER
PARTS & ACCESSORY MERCHANDISING

Number
13

Date
5-9-55

Subject

1955

ACCESSORY

FOLDER

FOR YOUR
PROSPECTS

FOR YOUR
OWNERS

FOR YOUR
SERVICE
CUSTOMERS



AMERICAN MOTORS CORPORATION

14250 PLYMOUTH ROAD

DETROIT 32, MICHIGAN

HUDSON AUTOMOBILES
NASH AUTOMOBILES
SPECIAL PRODUCTS

KELVINATOR
AND LEONARD
APPLIANCES

Accessory Merchandising Bulletin

Number

15

Date

5-18-55

Subject

TRAILER

HITCH

SUGGESTED
INSTRUCTIONS
ATTACHED

SOURCE OF
SUPPLY

ORDER BLANK
ATTACHED

More and more car owners are installing trailer hitches to haul utility as well as house trailers although the modern motor car is not specifically designed for this purpose.

Attached is SUGGESTED INSTRUCTIONS FOR TRAILER HITCHES for Hudson Wasp and Hornet Models which include advice regarding the abnormal problems due to hauling house trailers. They should be followed explicitly by all owners using this equipment. We recommend the instructions for serious reading by all Dealer personnel.

The Draw-Tite Company, Belleville, Michigan have available trailer hitches for application on all Hudson Models 1948 thru 1955.

A Dealer Order Blank is attached for ordering trailer hitches from the manufacturer. The order is placed direct with Draw-Tite Company and shipment made on a C.O.D. basis.

Additional copies of the instructions and order blanks are available on request to your Zone Office.

HUDSON MOTORS Division
American Motors Corporation

C. C. MC KELLAR

MANAGER
PARTS & ACCESSORY MERCHANDISING

SUGGESTED INSTRUCTIONS FOR HOUSE TRAILER EQUIPMENT

HUDSON WASP AND HORNET MODELS

CAUTION

It should be recognized by trailer owners that all makes of cars are designed and intended as a passenger conveyance. A trailer cannot be towed behind a passenger car without having some affect on safe operation., dependability and economy. Although the Hudson car will pull a trailer as satisfactorily as other makes of passenger cars, maximum efficiency will be derived through the use of proper equipment and by avoiding overloads and other abusive operation. When operating on highways, allowance must be made for the additional weight and bulk of the trailer, and driving habits must be altered accordingly.

AXLE OVERLOAD

It is imperative to avoid rear axle overload. Loads exceeding the design limits are likely to sacrifice durability. To determine axle load, weigh the car when loaded as it is to operate in actual service. Place the rear tires on the scale, and divide by two to obtain individual rear tire loading.

To assist in carrying loads up to design limits, the tire size and tire pressure as given in the following table should be strictly adhered to for either tube or tubeless tires. If the following table determines that the standard tires are overloaded, it will be necessary to use oversize or heavier capacity tires.

MODEL	TIRE SIZE	PLY RATING	LOADS AT VARIOUS INFLATIONS			
			24	26	28	30
Wasp	6:70-15	4	925			
Wasp	6:70-15	6	925	970	1015	1055
Hornet	7:10-15	4	990			
Hornet	7:10-15	6	990	1040	1085	1130

NOTE: PRESSURES IN EXCESS OF 24 POUNDS (cold check for 4 ply tires or 30 pounds for 6 ply tires) NOT RECOMENDED.

SPRINGS AND SHOCK ABSORBERS

Proper trim dimensions and suitable riding qualities are important. These can usually be obtained when trailer is attached by using heavy duty rear springs and shock absorbers. Hudson dealers have parts available for this application.

Important

When heavy duty rear shock absorbers are installed, it is also necessary that heavy duty shock absorbers be installed on the front of the car.

DRAW-TITE TRAILER HITCH

For Utility Trailers Up To 2000 pounds

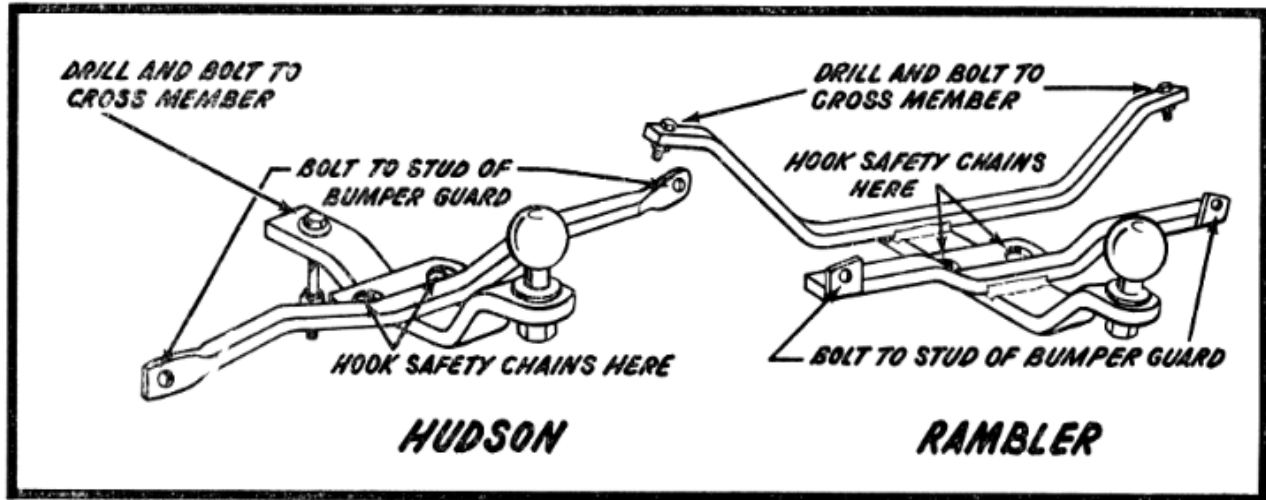

These Hitches Can Be Installed In 15 Minutes
CUSTOM BUILT TO FIT HUDSON CARS FROM 1948 TO DATE

PLEASE SPECIFY YEAR AND MODEL

- 220 HUDSON 1948 - 49 all models & 1950 - 51 Pacemaker
- 221 1950 - 51 Super, Commodore and Hornet
- 222 1952 - 53 - 54 all models
- 223 1953 - 54 Jet
- 208 1955 Hudson without wheel
- 209 1955 Hudson with wheel

- 205 1953 - 55 Rambler with wheel
- 206 1953 - 55 Rambler without wheel also Station Wagons

CADMIUM PLATED — COLD-ROLLED STEEL — STURDY

DEALER COSTS — Cadmium \$5.10 Chrome \$7.15

F.O.B. Draw-Tite Co. - Belleville, Michigan

Prices slightly higher West Coast and Texas

Draw-Tite Company ORDER BLANK Belleville, Michigan

Cadmium	Chrome	Ball Size	Model No.	Year and Model
				DRAW-TITE Hitches
				DRAW-TITE Hitches
				DRAW-TITE Hitches
				DRAW-TITE Hitches
				DRAW-TITE Hitches

Signed _____
 Street _____
 City _____ ★

(See other side for Heavy Duty Hitch)

DRAW-TITE HEAVY DUTY HOUSE TRAILER HITCH

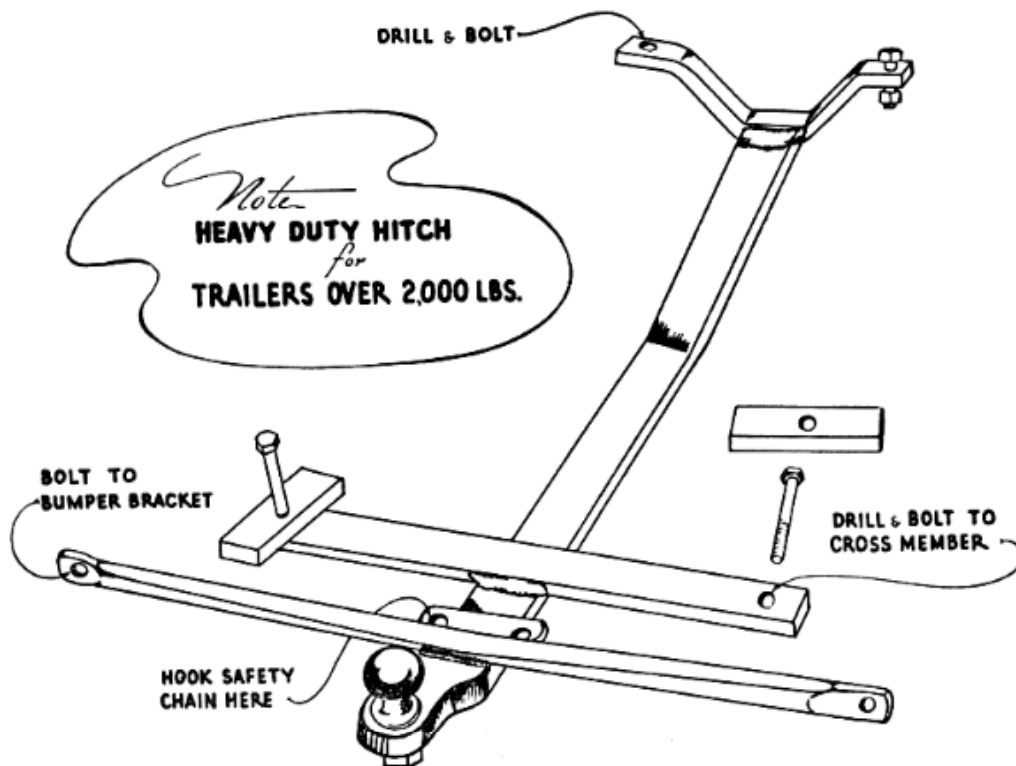

CUSTOM BUILT TO FIT HUDSON CARS FOR 1955

STURDY -- NEAT -- CADMIUM PLATED -- EASILY INSTALLED
"Nothing Shows But The Ball"

208 HT 1955 Hudson without wheel
 209 HT 1955 Hudson with wheel

Dealer Cost \$17.50

F.O.B. Draw-Tite Company
 Belleville, Michigan

Shipping Weight Approximately 63 Pounds

Draw-Tite Company ORDER BLANK Belleville, Michigan

PLEASE SHIP US

Model No. _____ DRAW-TITE Hitch

Signed _____

Street _____

City _____

(Use this side of Order Blank For Heavy Duty Hitches Only)
 (See Other Side For Light Utility Hitch)



AMERICAN MOTORS CORPORATION

HUDSON AUTOMOBILES
NASH AUTOMOBILES
HUDSON SPECIAL PRODUCTS

14250 PLYMOUTH ROAD
DETROIT 32 MICHIGAN

KELVINATOR
AND LEONARD
APPLIANCES

Accessory Merchandising Bulletin

You can offer your customers . . . THE MOST COMPLETE, FINEST RADIATOR COOLING SERVICE AVAILABLE.

HERE'S THE PRODUCTS. . . .

<u>GROUP NO.</u>	<u>PART NO.</u>	<u>DESCRIPTION</u>	<u>DEALER NET</u>	<u>E.O.H.</u>
15.100	8990142	Radiator Cleaning Kit	.51	T.E.
	8990143	Radiator Flush	.36	T.E.
	8990144	Radiator Rust Resistor	.27	T.E.
	8990145	Radiator Stop Leak	.30	T.E.
	8990040	Cooling System Sealer Lub	.60	T.E.

. . . . at prices that will please you and your customers.

HERE'S THE SALES AIDES . . . for promoting this "extra-profit" business.

2 - SALES POSTERS. . . a beautiful three colored retail selling piece for the Service Department and Parts Department. It sells by telling customers the story of Hudson's Cooling System Chemicals.

50 - MAILING PIECES . . . to include with customers statements . . . for handouts in Parts and Service Departments . . . for attachment to customer orders.

8 - SERVICE POSTERS . . . a poster with illustrations showing why a clean radiator is essential for "care-free" summer driving and how it improves the car's performance. The sales story of this poster is supported by three of today's leading television programs.

50 - RADIATOR DECALS . . . a decal for each cooling service job. A reminder to owners that his radiator was summer conditioned by his friendly Hudson Dealer.

DON'T DELAY, put this sales material to work immediately. . . featured with display of all the cooling service items.

"BE PREPARED, ORDER NOW"

Every service customer is a potential buyer
of radiator cooling system chemicals.

HUDSON MOTOR DIVISION
American Motors Sales Corporation

H. L. TEMPLIN

Parts & Accessory Merchandising

Number
16

Date
5-20-55

Subject
HUDSON
APPROVED
COOLING
SYSTEM
CHEMICALS
ARE

.
. .
"BEST"

SALES
P
R
O
M
O
T
I
O
N

ORDER

NOW



AMERICAN MOTORS CORPORATION

14250 PLYMOUTH ROAD
DETROIT 32 MICHIGAN

HUDSON AUTOMOBILES
NASH AUTOMOBILES
HUDSON SPECIAL PRODUCTS

KELVINATOR
AND LEONARD
APPLIANCES

Accessory Merchandising Bulletin

Number
20

CANCELLATION

Date
7-5-55

EFFECTIVE IMMEDIATELY

Subject

All price reductions on 1954 Accessories announced in Accessory Merchandising Bulletin No. 9 dated March 29th are hereby cancelled.

1954

The 1954 Accessories and reduced prices were included in Special Accessories Price List attached to the above bulletin.

ACCESSORY

Reduced prices on 1954 Accessories were also listed in the May 1st revised edition of the 1955 Accessory Price List. A new 1955 Accessories Price List will be issued deleting all 1954 items.

PRICE

REDUCTION

WITHDRAWN

Please notify all affected personnel and change your records accordingly.

HUDSON MOTORS Division
American Motors Corporation

C. C. MC KELLAR

MANAGER
PARTS & ACCESSORY MERCHANDISING